

ECOWATER
S Y S T E M S®



SINCE 1925.

Undersink
REVERSE OSMOSIS
DRINKING WATER SYSTEM

ERO-375
HERO-375

- ◆ Safety Guides
 - ◆ Installation
 - ◆ Operation
 - ◆ Maintenance
 - ◆ Repair Parts

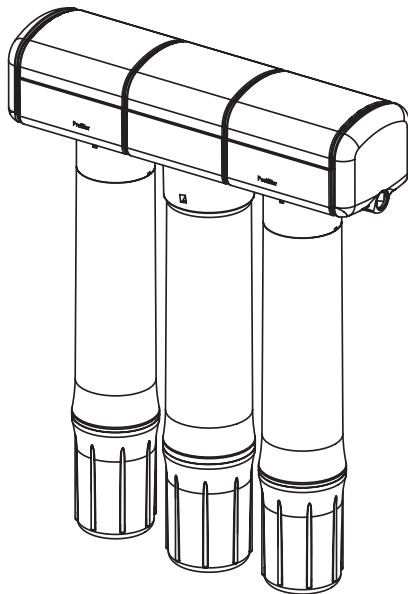

EcoWater Systems LLC
P.O. Box 64420
St. Paul, MN 55164
TEL (651) 739-5330

System tested and certified by NSF International
against NSF/ANSI Standard 58.
See performance data sheet for details.



7300493 (Rev. B 4/23/08)

TABLE OF CONTENTS

Warranty Information	2	Installing (or Replacing) Batteries	12
Safety Guides	3	Connecting Hydrolink™ RO Module to Remote . .	13
Specifications	4	How the Hydrolink™ RO Module Works	14
What the Drinking Water System Will Do	5	Status Screen on the Remote	14
Components of the System	5	Status LED on the Hydrolink™ RO Module	15
Checks to Make Before Installing	5	Checking RF Signal Strength	15
Installing	6-14	Changing the Remote Display	16-17
Feed Water Supply	6	How the RO System Works	18
Reject Water Drain Fitting	6	Replacing the Filters & RO Membrane	19
Installing Faucet	7	Care of Your Reverse Osmosis System	19-22
Installing RO Assembly & Storage Tank	8	Troubleshooting	22
Tubing Connections	9	System Schematic	23
Connect Water Supply, Storage Tank & Drain Tubing	10	Installation of Optional Fittings	24
Sanitizing / Pressure Testing / Purging	11	Remote Installation	25
Installing Hydrolink™ RO Module	12	Repair Parts	26-27

WARRANTY INFORMATION

LIMITED WARRANTY 1, 3, 5 and 10 YEAR

EcoWater Systems LLC, guarantees to the original owner that: for a period of ten (10) years from from the date of purchase, the RO holding tank will be free from defects in material and workmanship. All other parts of the drinking water system will be guaranteed for a period of five (5) years from defects in material and workmanship. The electronic faucet will be guaranteed for three (3) years from defects in material and workmanship. The reverse osmosis membrane will be guaranteed for one (1) year from defects in material and workmanship. The prefilters and postfilter, which are expendable, are not covered under this warranty. This warranty does not include normal shipping, installation or service charges.

Any defective part, as described above, which fails within the ten, five, three or one year period from date of purchase will be repaired or replaced, F.O.B. our plant, St. Paul, MN.

The sole obligation of EcoWater Systems LLC, under these guarantees, is to replace or repair the component or part which proves to be defective, within the specified time period, and EcoWater is not liable for consequential or incidental damages due to misuse, alteration, neglect, freezing or a force of nature. All implied warranties, including any implied warranty of merchantability or of fitness for a particular purpose, are disclaimed to the extent they extend beyond the above periods. No dealer, agent, representative, or other person is authorized to extend or expand these guarantees.

Some states do not allow limitations on how long an implied warranty lasts or exclusions or limitations of incidental or consequential damage, so the limitations and exclusions in this warranty may not apply to you. This warranty gives you specific legal rights, and you may have other rights which vary from state to state.

SAFETY GUIDES

◆ Read all steps, guides and rules carefully before installing and using the Drinking Water System. Follow all steps exactly to correctly install.

◆ **BE SURE TO FOLLOW APPLICABLE STATE AND LOCAL PLUMBING AND SANITATION CODES** when installing the Drinking Water System. Massachusetts plumbing code 248 CMR shall be adhered to. Please consult your licensed plumber. Using a qualified installer is recommended.

◆ The Drinking Water System works on water pressures of 40 psi minimum, to 100 psi maximum (see the table on Page 4). If house water pressure is over the maximum, install a pressure reducing valve in the water supply line to the Drinking Water System.

◆ This system is acceptable for treatment of influent concentrations of no more than 27 mg/L nitrate and 3 mg/L nitrite measured as N and is certified for nitrate/nitrite reduction only for water supplies with a pressure of 280 kPa (40 psig) or greater. This system is supplied with a nitrate/nitrite test kit. Product water should be monitored periodically according to the instructions provided with the test kit.

◆ **DO NOT** install the Drinking Water System outside, or in extreme hot or cold temperatures. Temperature of the water supply to the Drinking Water System must be between 40°F (minimum) and 100°F (maximum), see the table on Page 4. **DO NOT INSTALL ON HOT WATER.**

◆ Read the other limits (pH, water hardness, etc.), Page 4, and be sure the water supply conforms.

◆ Do not use with water that is microbiologically unsafe or of unknown quality without adequate disinfection before or after the system. Systems certified for cyst reduction may be used on disinfected water that may contain filterable cysts.

◆ This system shall only be used for arsenic reduction on chlorinated water supplies containing detectable residual free chlorine at the system inlet. Water systems using an inline chlorinator should provide a one minute chlorine contact time before the RO system. Conforms to NSF/ANSI 58 for pentavalent arsenic reduction. See performance data sheet and Arsenic Facts section for an explanation of reduction performance.

◆ **NOTE:** This equipment has been tested and found to comply with the limits for a Class B digital device, pursuant to Part 15 of the FCC Rules. These limits are designed to provide reasonable protection against harmful interference in a residential installation. This equipment generates, uses, and can radiate radio frequency energy and, if not installed and used in accordance with the instructions may cause harmful interference to radio communications. However, there is no guarantee that interference will not occur in a particular installation. If this equipment does cause harmful interference to radio or television reception, which can be determined by turning the equipment off and on, the user is encouraged to try to correct the interference by one or more of the following measures:

- Reorient or relocate the receiving antenna.
- Increase the separation between the equipment and receiver.
- Connect the equipment into an outlet on a circuit different from that to which the receiver is connected.
- Consult the dealer or an experienced radio/TV technician for help.

Changes or modifications not expressly approved by EcoWater Systems could void the user's authority to operate the equipment.

This device complies with **Industry Canada** Standard RSS-210. Operation is subject to the following two conditions: (1) this device may not cause interference, and (2) this device must accept any interference, including interference that may cause undesired operation of the device.

Ce dispositif est conforme avec la norme CNR-210

d'Industrie Canada. Le fonctionnement du dispositif est sujet aux deux conditions suivantes: (1) le dispositif ne doit pas causer de brouillage, et (2) le dispositif doit accepter tous brouillages, incluant tous brouillages qui peut nuire au bon fonctionnement du dispositif.



European Directive 2002/96/EC requires all electrical and electronic equipment to be disposed of according to Waste Electrical and Electronic Equipment (WEEE) requirements. This directive or similar laws are in place nationally and can vary from region to region. Please refer to your state and local laws for proper disposal of the equipment.

SPECIFICATIONS

Feed water pressure limits - pounds per square inch (psi)	40 - 100
Feed water temperature limits - minimum / maximum degrees F	40 - 100
Maximum total dissolved solids (TDS) - parts per million (ppm)	2000
Maximum water hardness @ 6.9 pH - grains per gallon (gpg)	10
Maximum iron, manganese, hydrogen sulfide.	0
Chlorine in water supply	allowable ♦
Feed water pH limits (pH)	4 - 11
Product (quality) water, 24 hours - gallons ● (closed system).	17.4
Percent rejection of TDS, minimum (new membrane) ●	95
Automatic shutoff control	yes
Efficiency ■	10.14
Recovery □	18.98

♦ Chlorine reduction (max. of 2.0 ppm) by the RO Prefilter. **REGULAR MAINTENANCE REQUIRED.** Chlorine will destroy the RO membrane, See Page 5.

● Feed water supply at 50 psi, 77°F, and 750 TDS - Quality water production and percent rejection all vary with changes in pressure, temperature and total dissolved solids.

■ Efficiency rating means the percentage of the influent water to the system that is available to the user as reverse osmosis treated water under operating conditions that approximate typical daily use.

□ Recovery rating means the percentage of the influent water to the membrane portion of the system that is available to the user as reverse osmosis treated water when the system is operated without a storage tank or when the storage tank is bypassed.

This system conforms to NSF/ANSI 58 for the specific performance claims as verified and substantiated by test data.

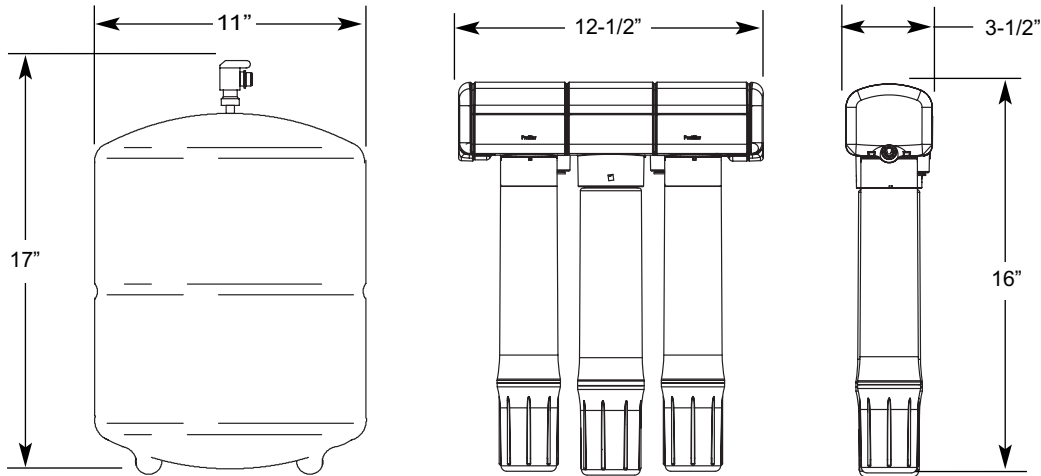

PRETREATMENT OF THE WATER SUPPLY NEEDED TO PREVENT SCALING

TO USE THE CHART...

...Locate the intersecting point of feed **water hardness** and **pH**.

If this point falls within the shaded area, pretreatment* is needed.

*Softening of the water is the suggested pretreatment.

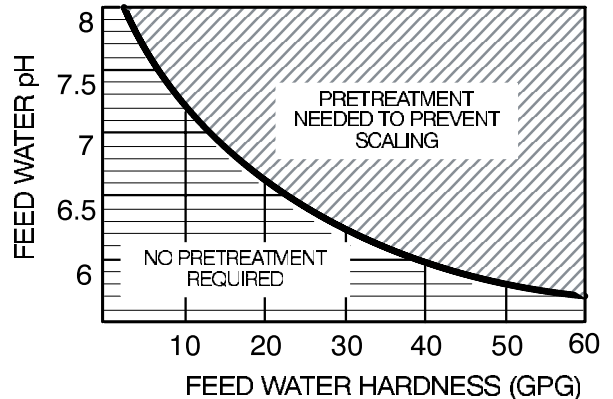

WHAT THE DRINKING WATER SYSTEM WILL DO

The drinking water system is a REVERSE OSMOSIS (RO) water treating unit. Reverse osmosis is a way of reducing dissolved solids and organic matter from water by passing it through a special membrane. The membrane separates minerals and impurities from the water, and they are flushed to the drain. Good tasting, high quality product water goes directly to the drinking water faucet, or to the storage area. The system makes a good supply of drinking water each day (see specifications). How much it will make depends on the feed water supply pressure, temperature, and quality.

Pre and postfilters are replaceable cartridges. The carbon prefilter reduces some chlorine (see specifications) while also filtering sediments. The postfilter reduces any other undesirable tastes and odors before you use the water.

The RO system also includes a standard faucet assembly to vend the drinking water, and a storage tank.

NOTE: A performance data sheet is included listing what the system will reduce from the water supply. See performance data sheet for individual contaminants and reduction performance.

The drinking water system fits under the kitchen or bathroom sink. However, you can install it where most convenient. You do need a COLD water supply pipe and drain point within a few feet (6' tubing lengths included). You can buy longer lengths of tubing if needed to reach more distant points. Be sure tubing is acceptable for use on potable water supplies.

COMPONENTS OF THE SYSTEM

The RO system is shipped in one carton, consisting of:

- (1) Storage Tank,
- (2) Faucet,
- (3) RO Assembly, with color coded tubing lengths attached,
- (4) Parts bag containing storage tank shutoff valve, drain flow restrictor, mounting washers and screws.
- (5) Separate 30" length of 3/8" tubing.
- (6) Hydrolink™ RO Module, with batteries and cable, in its own box (Model HERO-375 only).

INSTALLER PROVIDES: (1) fittings to tap the cold water pipe for a feed water source to the RO . . . must adapt to 1/4" tubing; and (2) a drain point for RO discharge water . . . must adapt to 3/8" OD tubing. Both items must comply with state and /or local codes. Optional fittings are available from EcoWater for use in areas where codes permit.

THINGS TO CHECK BEFORE YOU START TO INSTALL:

★ **FEED WATER** - The water supply to the Drinking Water System must have the qualities listed in the specifications. If not, it will not make product water as it should and life of the RO membrane is shortened. City water most often will have these qualities. Well water may need conditioning. Have the water tested by a water analysis laboratory, and get their recommendations for treatment. Observe plumbing codes when providing a water supply to the RO. A self-piercing saddle valve is available for tapping into a cold water pipe (check local plumbing codes). Refer to Pages 24 and 27.

NOTE: Codes in the state of Massachusetts require installation by a licensed plumber, and do not permit the use of the drain clamp. For installation, use plumbing code 248-CMR of the Commonwealth of Massachusetts.

CAUTIONS:

Feed water must have chlorine reduced (prefilters reduce up to amount shown in specifications, Page 4). Chlorine will destroy the RO membrane cartridge. Be sure to service the prefilters, Page 19.

★ **DRAIN POINT** - A suitable drain point (check your local plumbing codes) is needed for reject water from the RO membrane cartridge. Running the RO drain tubing directly to a floor drain, laundry tub, sump, standpipe, etc., is preferred. If that is not possible or practical, using the sink p-trap drain pipe is suggested. A drain clamp (drilling required), or a special drain adapter are available from EcoWater to use where codes permit. Refer to Pages 24 and 27. These options install on the sink drain pipe tailpiece, above the p-trap.

★ **RO FAUCET** - The RO product water faucet installs on the sink, or on the countertop next to the sink. Often, it's installed in an existing sink spray attachment hole. Space is required underneath for tubing to and from the faucet, and for securing it in place. Refer to Pages 7 and 10.

★ **MOUNTING SURFACE** - The RO assembly mounts on a wall surface under the sink, or you can lay it on the bottom of the cabinet. Special washers and screws are included for wall mounting. When the storage tank is full of water, it weighs about 30 pounds. Be sure to set on a surface that will support this weight.

INSTALLATION - FEED WATER SUPPLY

Check and comply with local plumbing codes as you plan, then install a cold feed (supply) water fitting. The fitting must provide a leak tight connection to the RO 1/4" OD tubing, see Figure 6, Page 10. A typical installation, using standard plumbing fittings is shown in Figure 1. A saddle valve (part no. 7011272) is available to use where codes permit. Installation instructions are on Page 24.

NOTE: Codes in the state of Massachusetts require installation by a licensed plumber, and do not permit the use of the drain clamp. For installation, use plumbing code 248-CMR of the Commonwealth of Massachusetts.

PIPE FITTINGS (compression shown)

IMPORTANT: Before starting, close the hot and cold water shutoff valves (See Figure 1). Use a pan to catch water when disassembling the pipe.

Complying with plumbing codes, install a fitting on the kitchen cold water pipe to adapt 1/4" OD tubing. A typical connection is shown in Figure 1. You can use solder or threaded fittings. If threaded fittings are used, be sure to use pipe joint compound or Teflon tape on outside threads.

Do not connect the tubing to the fitting until Step 2, top of Page 10.

FIGURE 1

WATER SUPPLY TYPICAL CONNECTION
(using compression fitting)

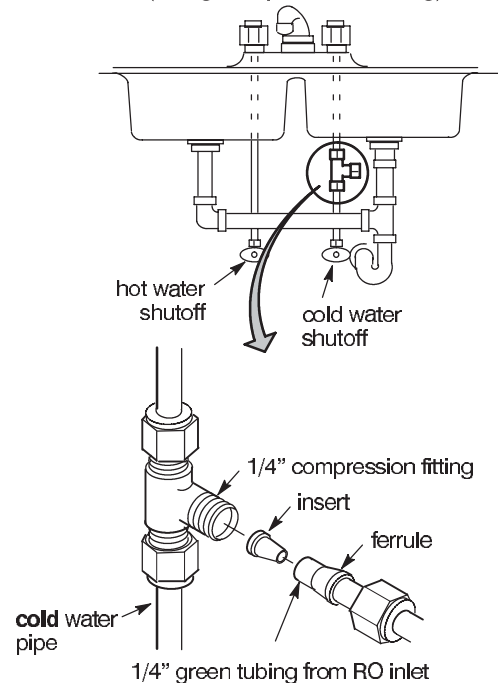

REJECT WATER DRAIN FITTING

Running the RO drain tubing directly to a floor drain, laundry tub, sump, standpipe, etc., is preferred. If that is not possible or practical, check and comply with local plumbing codes as you plan, then install a drain fitting for RO reject water. This fitting is usually installed at the sink p-trap (always above). It must provide a leak-tight connection to 3/8" OD tubing from the RO product water faucet airgap, see Figure 6, Page 10. Typical drain fitting installations are listed below. A drain adapter (part no. 7192230) is available to use where codes permit. Installation instructions are on Page 24. Other options are shown on Page 27.

"Y" BRANCH TAIL PIECE, OR OTHER APPROVED P-TRAP DRAIN

Reject water from the RO is routed to the RO faucet airgap (1/4" tubing), then to the drain point with 3/8" OD tubing. **COMPLYING WITH PLUMBING CODES,** install a fitting to accept the 3/8" tubing. Figure 2 shows typical p-trap and "Y" branch tail piece type drains.

Do not connect drain tubing until Step 1, top of Page 10.

FIGURE 2

DRAIN TYPICAL CONNECTION
(check local codes)

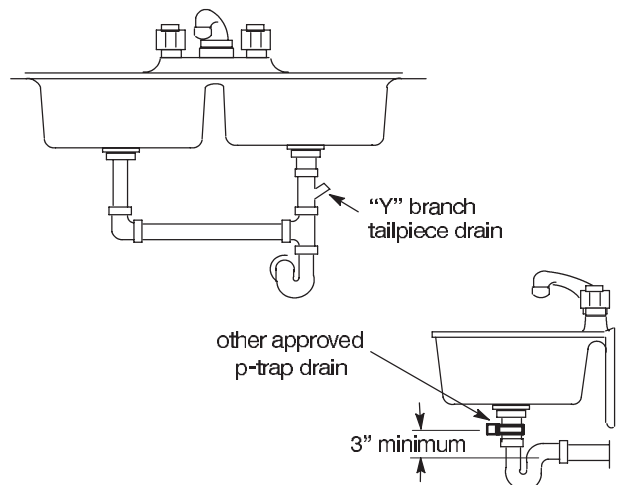

INSTALL THE FAUCET

Select one of the following places to install the faucet. Be sure there's room underneath so you can make the needed connections.

- ◆ In an existing sink spray attachment hole.
- ◆ Drill a hole in the sink top.
- ◆ Drill a hole in the countertop, next to the sink.

NOTE: Looking at Figure 3, be sure the faucet base will fit flat against the surface at the selected location so the o-ring will seal.

1. Do not connect drain tubing until Step 1, top of Page 10.

2. For Model ERO-375, slide the chrome washer onto the faucet stud, Figure 3.

3. For Model HERO-375, snap the o-ring in the groove on the bottom of the ring and slide the monitor ring onto the faucet stud. The monitor ring LED wire must be routed through the sink or countertop hole and through the spacer, if used, Figure 3.

NOTE: If you will route the RO drain tubing directly to the drain point, disregard Steps 4 and 6 and do Step 1 on top of Page 10.

4. Take the 30" length of 3/8" black tubing and push one end onto the 3/8" faucet barb fitting, Figure 4.

5. Move the RO system into position, under the sink. (Referring to Page 8, hang the system on cabinet wall, or lay on the floor surface, as desired.)

6. Route the 1/4" red tubing from the bottom, up through the faucet mounting hole. Push the end of the tubing onto the 1/4" barb fitting.

7. Work tubing and the faucet stud down, into the mounting hole.

8. On the underside of the sink or countertop, install the spacer (Model HERO-375 only), plastic bushing, flat washer, and hex nut. Slide the large steel washer in place, between the bushing (or spacer) and the bottom of the sink or countertop. Then, tighten the hex nut securely. Make sure that the LED wire is in a position so that it will not be cut, pinched or kinked before tightening the faucet assembly.

9. Thread the tubing connector onto the bottom of the faucet stud.

10. Push the end of the 3/8" blue tubing from the RO, into the tubing connector installed in Step 9.

NOTE: See tubing connection procedures on Page 9. For ease of service and maintenance, keep tubing lengths long enough so removal of the RO system from under the sink is possible.

FIGURE 3 - FAUCET INSTALLATION

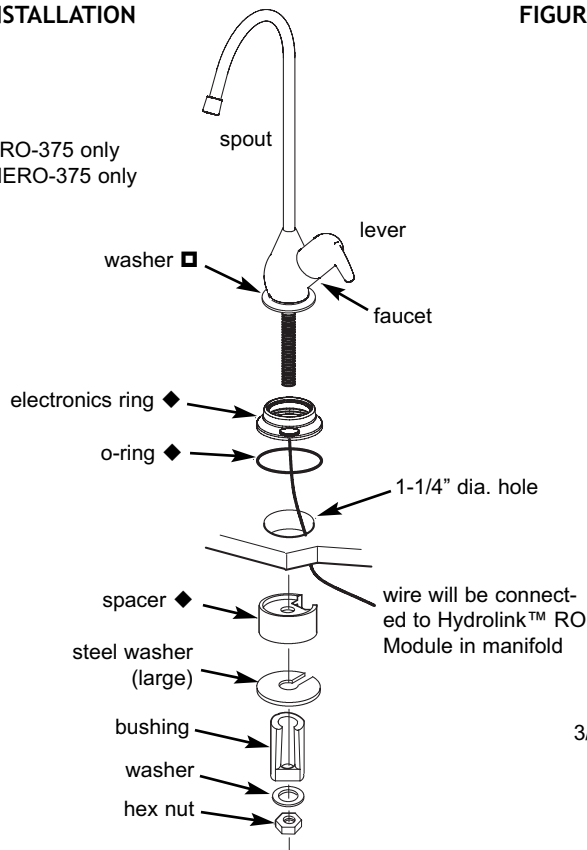
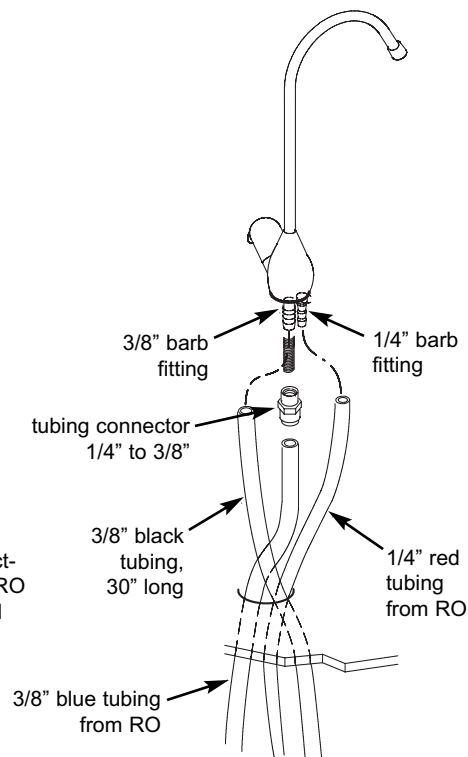

FIGURE 4 - TUBING CONNECTIONS



INSTALL RO ASSEMBLY AND STORAGE TANK

1. Hold the RO assembly up to the wall surface where you will install it. Mark locations for the hanger washers and screws.

2. Fasten the hanger washers to the wall surface. Wood screws are included for fastening to a wood surface. Provide other screws for other surfaces as needed.

3. Hang the RO assembly on the hanger washers.

4. Move the storage tank into place, setting on the floor surface. Use the stand, included with the tank, and position the tank upright, or on its side.

5. Apply teflon tape on the tank nipple threads and install the shutoff valve.

FIGURE 5

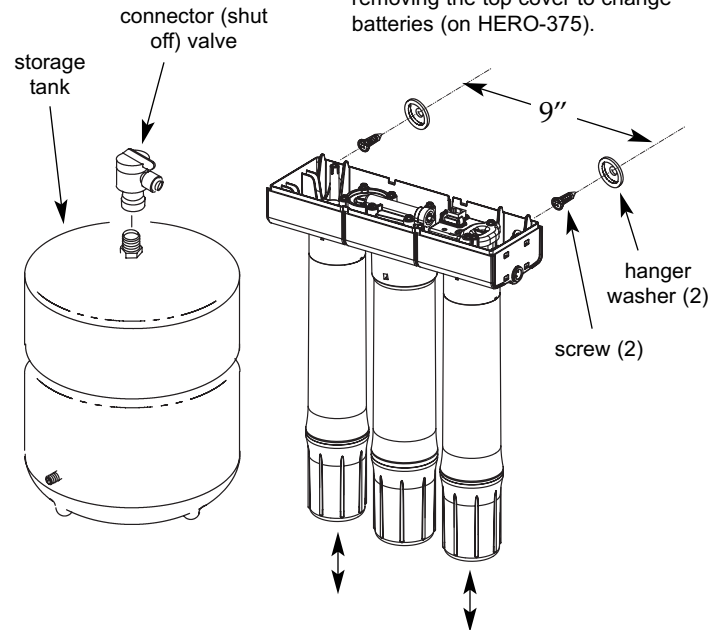

NOTE: Be sure to allow a minimum space of 4" above the system for removing the top cover to change batteries (on HERO-375).

NOTE: Be sure to allow a minimum space of 1-1/2" under the system for removing the cartridges in order to change them.

TUBING CONNECTIONS

HOW TO CUT AND CONNECT THE TUBES

Your Reverse Osmosis Water System includes push-in fittings for quick tubing connection. Review the following instructions before connecting the tubes in the next step.

Cut tubes to length

1. Use a sharp cutter or knife to cut the end of tubing. Always cut the tubing square.
2. Inspect the end (about 1") of the tubing to be sure there are no nicks, scratches or other rough spots. If needed, cut the tubing again.

NOTE: Tubing lengths should allow for the removal of the assembly from the hanger washers for servicing. If tubing lengths are shortened for neater appearance, it may be necessary to keep the assembly on the hanger washers for service.

Connect tubes

1. Push tubing through collet, until it engages the o-ring. Continue pushing until the tube bottoms out against the back of the fitting. A common mistake is to stop pushing when the tube engages the o-ring. This will lead to future leaks. When a 1/4" tube is fully engaged, 11/16" of the tube has entered the fitting. When a 3/8" tube is fully engaged, 3/4" of the tube has entered the fitting.

2. If using tubing other than tubing supplied with the system, be sure it is of high quality, exact size and roundness with a smooth surface.

Disconnect Tubes

1. Push the collet inward with a finger tip.
2. Continue holding collet inward while pulling the tubing out.

Tube Correctly Cut

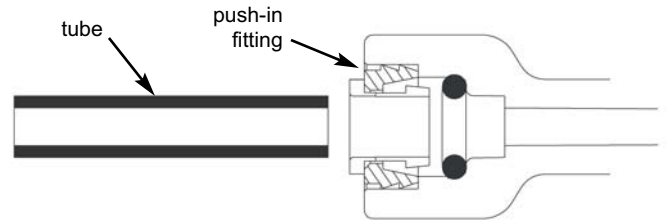

Cut tubing square with end of tubing round, smooth, with no cuts, nicks or flat spots.

Tube Partially Engaged With Fitting

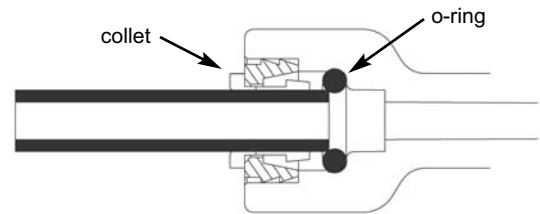

Tube Fully Engaged With Fitting

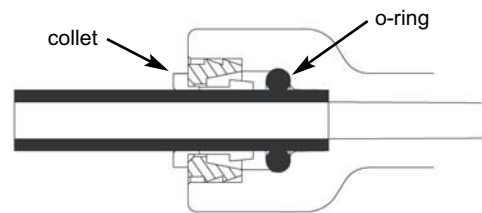

Disconnect Tubing

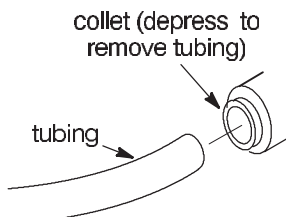

Collet and O-ring

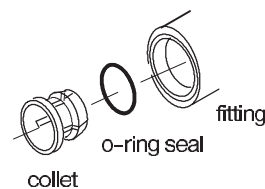

CONNECT WATER SUPPLY, STORAGE TANK AND DRAIN TUBING

1. Connect faucet drain tubing (if using p-trap drain): Run the 3/8" black tubing from the 3/8" faucet barb, to the drain fitting installed on page 6. Keep this tubing run as straight as possible, without loops, dips or low-spots. Cut the tubing as needed and fasten to the drain fitting, securing as required (pages 6 and 24).

Or, connect RO drain tubing (if using floor drain or other approved drain point): Route the 1/4" red tubing from the RO to the floor drain, sump, etc. Be sure to provide an air gap when securing in place.

2. Install Flow Control Insert: Before connecting the 1/4" red tubing to the RO system manifold's drain port, take the flow control insert from the parts bag and insert it into the end of the tube, as shown below.

3. Connect water supply tubing: A length of 1/4" green tubing is attached to the RO inlet. Connect this tubing to the feed water supply fitting, installed on page 6. Connect the tubing as applies (Figures 1 and 6) and tighten the nut securely.

FIGURE 6 - TYPICAL INSTALLATION

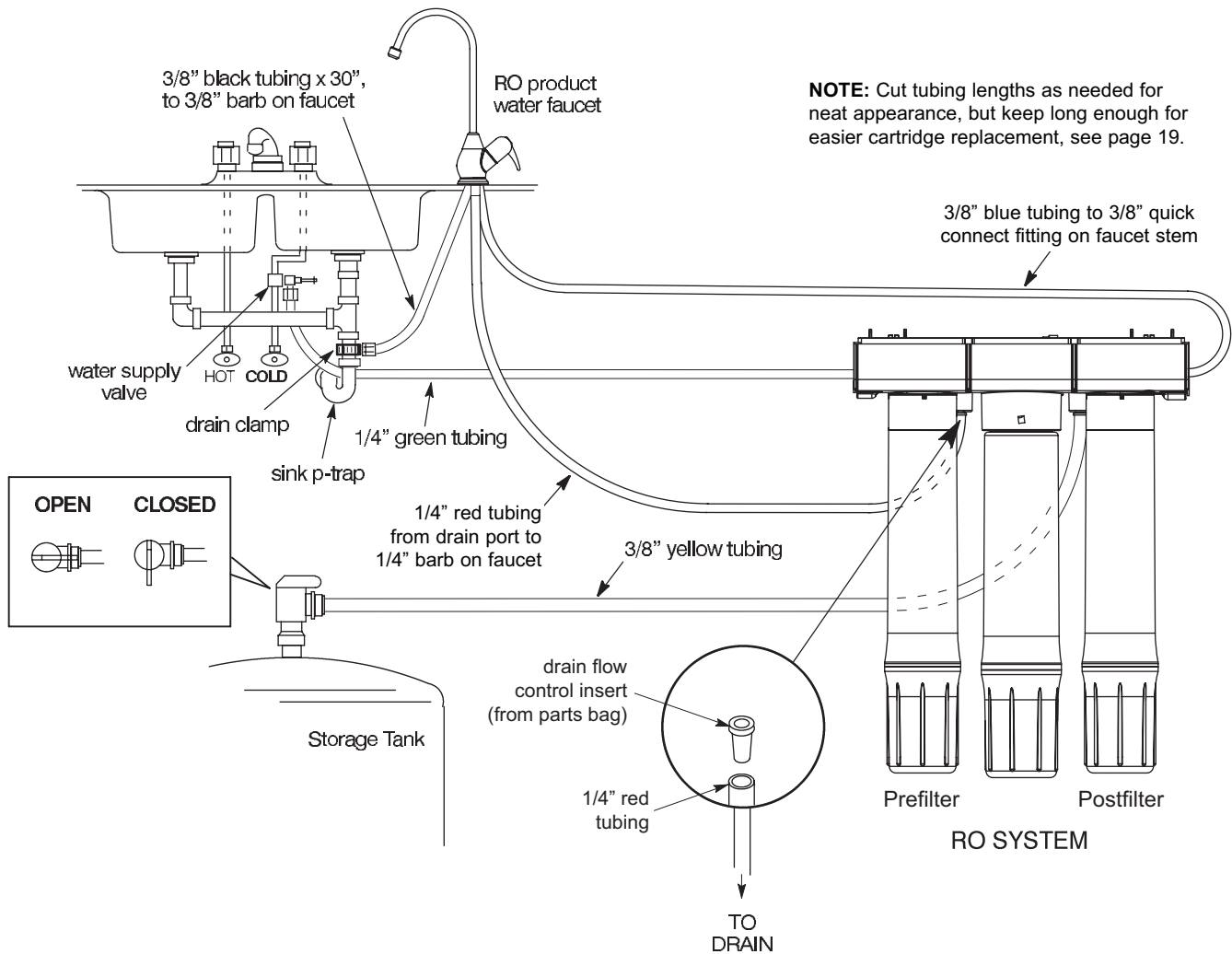

SANITIZING THE RO SYSTEM

SANITIZE THE SYSTEM

Sanitizing is recommended immediately after installation of the Reverse Osmosis system. It's also recommended after servicing inner parts. It is important that the person installing or servicing the system have clean hands while handling inner parts of the system.

Complete the following steps to sanitize the system.

1. Turn off the water supply to the Reverse Osmosis system, or remove prefilter to automatically shut off water supply.
2. Open the Reverse Osmosis faucet. If the tank is not already empty, allow the water to empty.
3. Use an eyedropper or other suitable tool, and com-

mon household bleach (5.25%).

4. Add 3 mL. of bleach into open end of yellow tank tubing. Handle bleach according to bleach manufacturer recommendations.

5. Connect yellow tank tubing to tank connector. Run the length of 3/8" yellow tubing from the RO to the connector (shutoff) valve at the top of the storage tank (Figure 6).

6. Sanitizing the system will be completed during the pressure test and purging steps below.

NOTE: The bleach must be removed from the system before drinking the water. See purging instructions below.

PRESSURE TESTING

DO THE PRECEDING SANITIZING PROCEDURES BEFORE PRESSURE TESTING.

1. Open the water supply shutoff valve to the RO.
2. Open the main water supply valve and several house faucets to purge air from the system. Close faucets when water runs smooth.

3. Open the shutoff valve on the RO water storage tank.

4. In about two hours, pressure will start to build in the RO system. Then, carefully check all fittings and connections for water leaks. Correct leaks if any are found.

PURGING THE SYSTEM

To purge the system, complete the following steps.

1. Open the RO faucet and let water flow through the system for a 24 hour period.

NOTE: Water flow may be a slow trickle at this time.

2. Close the RO faucet after the 24 hour purging period is complete.

3. When the purging is finished, your Reverse Osmosis system is ready for use.

INSTALL THE HYDROLINK™ RO MODULE (Model HERO-375 Only)

WIRING CONNECTIONS



1. Locate the cable packed with the Hydrolink™ RO Module. One end should be plugged into the telephone-style receptacle identified by the RO icon: 
2. Plug the other end into the RO electronics receptacle on the top the RO manifold assembly (See Figure 7).
3. Locate the the wire from the monitored faucet and plug its connector into the Hydrolink™ RO Module receptacle identified by the faucet icon: 

FIGURE 7



INSTALLING (OR REPLACING) BATTERIES (Model HERO-375 Only)

1. Remove the battery cover from the Hydrolink™ RO Module (See Figure 8).
2. Install three (3) AAA size batteries, making sure that they are oriented to match the markings inside the battery compartment.
3. Snap the battery cover back in place.
4. When the batteries are first installed at initial start up, the LED indicator light on the Hydrolink™ RO Module will begin flashing (the LED on the faucet base will also flash in a red, amber, green sequence).

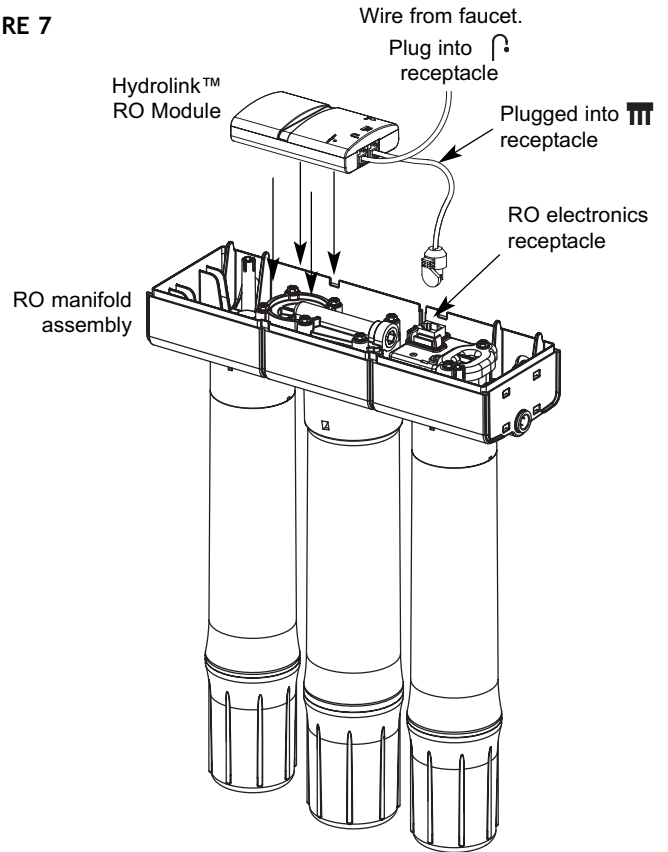
NOTE: Do not install a coin battery in the holder next to the LED. The coin battery holder is for systems **not** equipped with a Hydrolink™ RO Module.

FIGURE 8

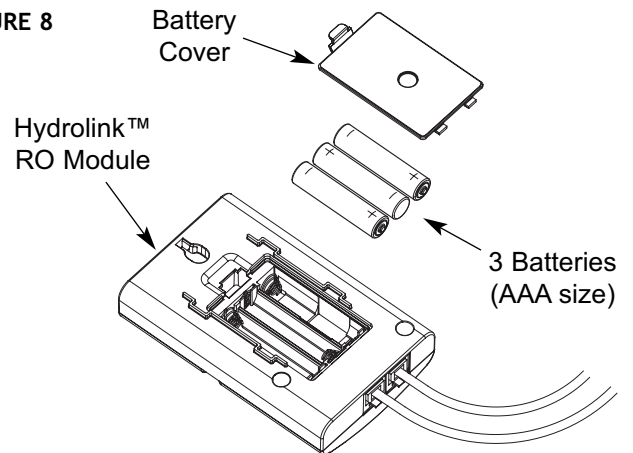
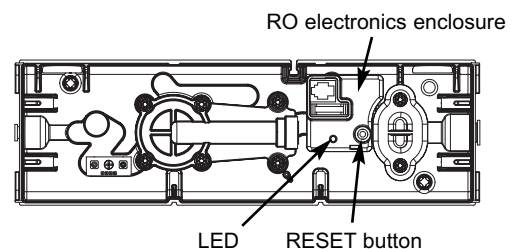

FIGURE 9



CONNECT THE HYDROLINK™ RO MODULE TO THE REMOTE (Model HERO-375 Only)

NOTE: If you do not have a Hydrolink™-equipped water conditioner (with remote), skip this procedure. The RO electronics and the indicator light on the faucet base will function normally, as described on Page 18.

1. Locate the remote for your Hydrolink™-equipped water conditioner or refiner. From any of the rolling status screens, press the SELECT (O) button to display a **menu**.

2. Press the remote's DOWN (▼) button to scroll through the menu options until **Add new device** is highlighted.

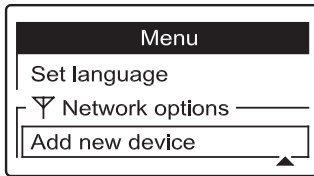

3. Press the remote's SELECT (O) button, and the screen shown below is displayed. The remote waits two minutes for the Hydrolink™ module to be activated (as described in the next step).



FIGURE 10

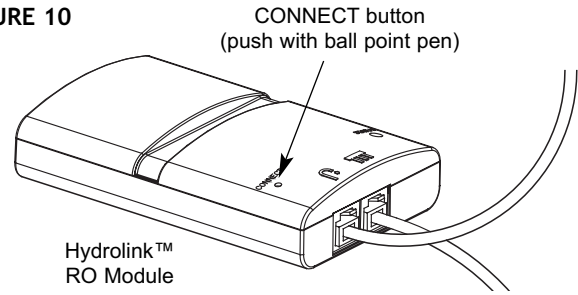

4. Using a ball point pen or similar probe, press the CONNECT button on the Hydrolink™ RO Module (See Figure 10) and hold it down for at least two seconds, until the LED on the Hydrolink™ RO Module begins to flash, then release.

5. When the remote detects a signal from the Hydrolink™ RO Module, the display will change to show the following screen.



6. If another message appears instead, indicating a device was not added successfully, press the remote's LEFT (◀) button to return to the screen shown under Step 2. Repeat Steps 3 and 4.

POSITION HYDROLINK™ RO MODULE UNDER RO COVER (Model HERO-375 Only)

1. Place the Hydrolink™ RO Module into the RO manifold assembly, where shown in Figures 11 & 12. Route the wire as shown in Figure 11 and carefully push it down into the recesses on the manifold assembly while holding the Hydrolink™ RO Module in place.

2. Snap the cover onto the RO manifold assembly, making sure that the Hydrolink™ RO Module is lined up as shown in Figure 12.

FIGURE 11

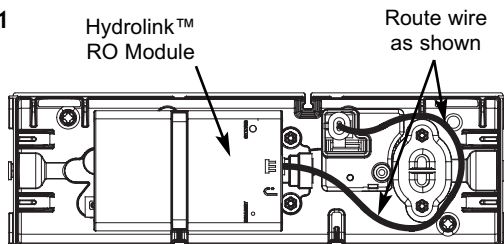
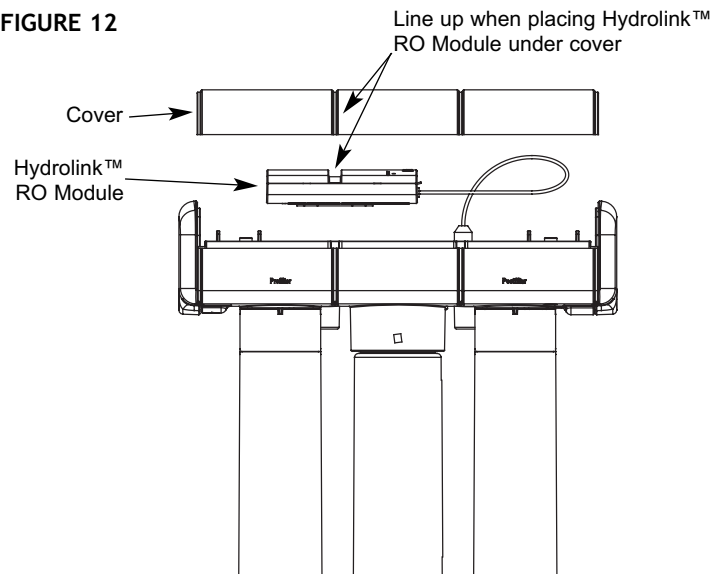

FIGURE 12



HOW THE HYDROLINK™ RO MODULE WORKS (Model HERO-375 Only)

FIGURE 13

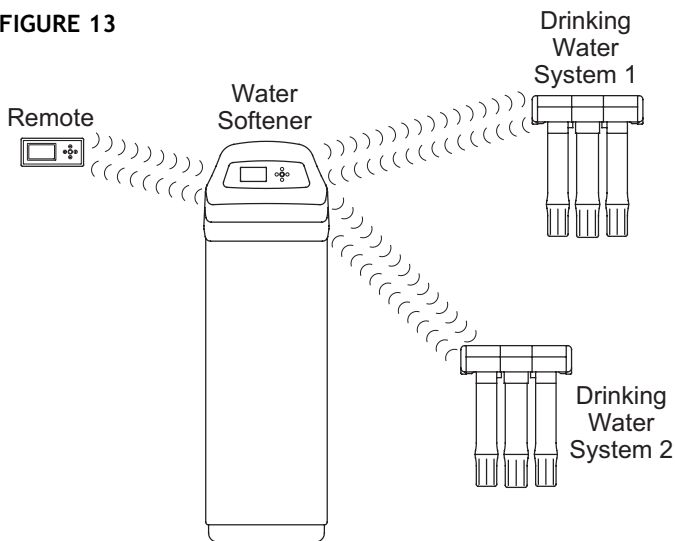
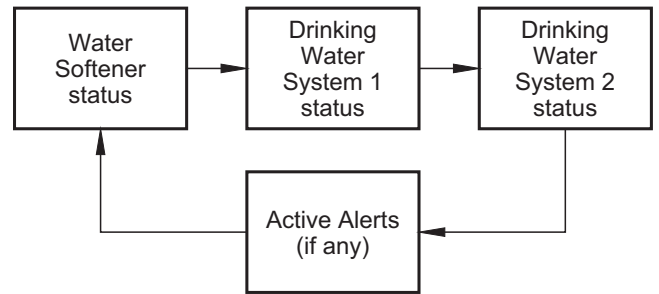

FIGURE 14



HYDROLINK™ RO MODULE

The EcoWater Systems Hydrolink™ RO Module is part of a wireless system which monitors multiple water treatment devices in a home. These water treatment devices include water softener(s) and drinking water filter(s) equipped to communicate with this type of system (See Figure 13). The remote displays, in a convenient, central location, useful operating information.

Once devices capable of communicating with the system have been added to the remote (See “Connect the Hydrolink™ RO Module to the Remote” on Page 13), the remote’s normal operating mode displays a sequence of screens showing the status of each device in the system (See Figure 14), and any active alerts, such as “Replace filters.”

HYDROLINK™ COMMUNICATION SYSTEM

The devices in the system exchange information in a loosely coupled network. AC powered devices, such as softeners, listen for new data all the time and act as data hubs. Battery powered devices like the remote check for information at regular intervals. Battery powered devices like drinking water systems do not communicate directly with each other or the remote, but pass along information through AC powered devices. Up to 6 devices may be added to one remote, including no more than 3 EcoWater Systems 3500 series water softeners. An AC powered device with a transmitter must be part of any network (usually a water softener).

It is not necessary for every device in a network to be in radio range of all others. Information one device communicates to any other device will be passed along (like gossip) to all devices in the network.

STATUS SCREEN ON REMOTE

When the Hydrolink™ RO Module has been connected to the remote it will have a status screen on the remote that alternates with other devices in the system as shown above.

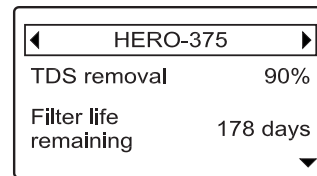

The normal status screen will look like the one shown above, and will display the following data items from the RO:

<u>DATA ITEM</u>	<u>REMOTE DISPLAY UPDATED EVERY</u>
● TDS* removal (%)	2 hours
● Filter life remaining (days)	2 hours
● Average daily use (gallons/liters)	2 hours
● Water dispensed** (gallons/liters)	2 hours

*Total dissolved solids.

**Water output through faucet since the last filter change, not including water currently stored in tank.

Use the remote’s DOWN (▼) and UP (▲) buttons to scroll through the entire list of items.

ACTIVE ALERTS

The normal status screen, described above, will not be displayed in a rolling sequence when one of the following active alert messages is displayed:

- **Replace filters** (See Page 19 for filter replacement instructions)
- **Replace membrane** (See Page 19 for membrane replacement instructions)
- **Replace batteries** (See Page 12 for battery replacement instructions)
- **No RO system found** (May indicate that the cable between the Hydrolink Module and RO electronics is not properly connected, as shown on Page 12).

STATUS LED ON THE HYDROLINK™ RO MODULE (Model HERO-375 Only)

The LED on the Hydrolink™ RO Module indicates status of the unit's operations, as shown in the table:

LED Indication	Status
Not Flashing	Batteries dead or RO electronics not detected
Short Flash every 15 seconds	Normal operation
Steady Flashing once per second	Busy (normal at startup and when connecting to remote)
Fast Flashing (twice per second) for 5 seconds	Error (RO electronics not detected)

CHECKING THE RF SIGNAL STRENGTH (Model HERO-375 Only)

After the Hydrolink™ RO Module has been added to the remote, it is useful to check the signal strength on the remote:

1. Have the remote in its intended location.
2. Press the remote's RIGHT (▶) or LEFT (◀) buttons to advance to the status screen for the HERO-375.

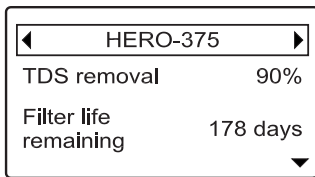

3. With the HERO-375 status screen displayed, press the SELECT (○) button to display the HERO-375 menu.
4. Press the DOWN (▼) button to scroll through the menu options until **RF signal strength** is highlighted in a box (as shown below).

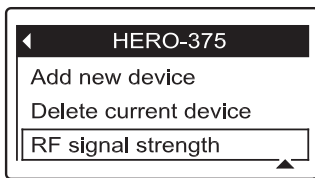

5. Press the SELECT (○) button, and the screen shown below will appear. The more bars that are filled in black, the stronger the signal. The signal strength display updates every 15 seconds.

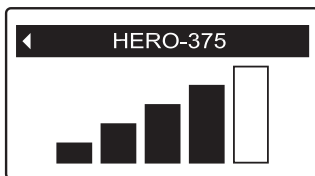

6. To exit this screen, press the LEFT (◀) button.

If the signal strength is weak (2 bars or less on the display), check the RF signal strength of the softener. As described on Page 14 (Hydrolink™ Communication System), during normal operation the RO communicates indirectly with the remote, using the softener to relay information. Checking the signal between the softener and remote may help to identify which is the "weak link" in the chain.

Check the softener's RF signal strength by going back to the rolling status screens, advancing to the softener status screen, pressing SELECT (○) and repeating steps 4 and 5. Since the RO communicates with the remote through the softener, the link between the softener and remote may be the weak one. Remedies for low signal strength include moving the remote to a different location and checking again.

If the signal strength of the RO is very weak compared with the softener's signal, it may be necessary to take the Hydrolink™ RO Module out from under the RO system cover and mount it to the wall vertically (See Figure 15) There is a recess on the back of the module for hanging it from a fastener (not included).

FIGURE 15

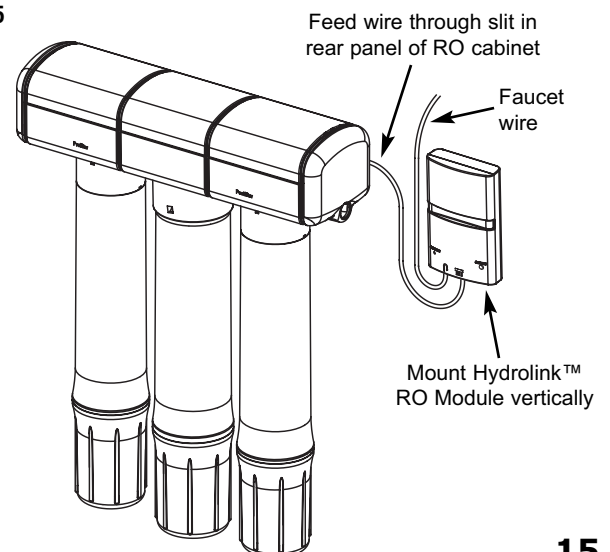

CHANGING THE REMOTE DISPLAY (Model HERO-375 Only)

CHANGING WHICH DATA ITEMS ARE DISPLAYED IN THE STATUS SCREEN

The HERO-375 status screen on the remote (See Page 14) may be customized to turn on or off any or all of the items listed below:

DATA ITEM

- TDS* removal (%)
- Filter life remaining (days)
- Average daily use (gallons/liters)
- Water dispensed** (gallons/liters)

*Total dissolved solids.

**Water output through faucet since the last filter change, not including water currently stored in tank.

To turn data items on or off:

1. Press the remote's LEFT (◀) or RIGHT (▶) buttons to manually advance to the HERO-375 status screen.
2. Press the remote's SELECT (○) button to display the HERO-375 menu.
3. Press the DOWN (▼) button to scroll through the menu until **Display data** is highlighted in a box.

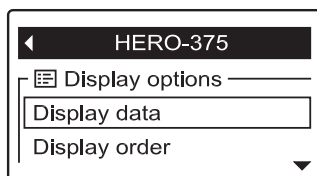

4. Press the SELECT (○) button to display the display data screen.

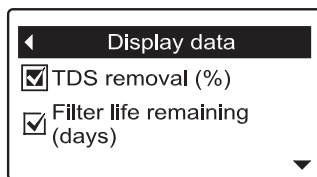

5. Press the DOWN (▼) or UP (▲) buttons to scroll through the list of display data items. Items with a check mark in the box next to them will be displayed during normal operation.

6. To select an unchecked display data item, make sure the box next to the item's name is highlighted (box is black inside). Then press the SELECT (○) button. The check mark will appear in the box.

7. To un-select a checked display data item, make sure the box next to the item's name is highlighted (box is black inside). Then press the SELECT (○) button. The check mark will disappear.

8. When selections are complete, exit this menu by pressing the LEFT (◀) button twice.

NOTE: If you turn off all data items, there will still be a status screen for the HERO-375 on the remote, but it will be blank below the header.

CHANGING THE ORDER OF DATA ITEMS DISPLAYED IN THE STATUS SCREEN

In addition to changing which data items the remote displays during normal operation, the order of these items may be customized, as follows:

1. Press the remote's LEFT (◀) or RIGHT (▶) buttons to manually advance to the HERO-375 status screen.
2. Press the remote's SELECT (○) button to display the HERO-375 menu.
3. Press the DOWN (▼) button to scroll through the menu until **Display order** is highlighted in a box.

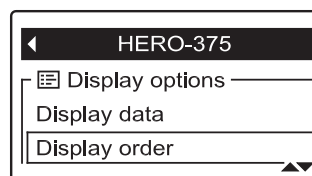

4. Press the SELECT (○) button to display the display order screen.

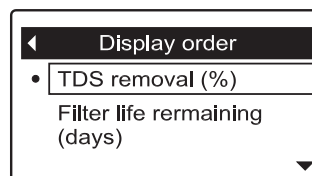

5. Press the DOWN (▼) or UP (▲) buttons to scroll through the list of display data items. Stop when the item you want to move is highlighted in a box.

6. Press the SELECT (○) button. Arrows will appear next to the item.

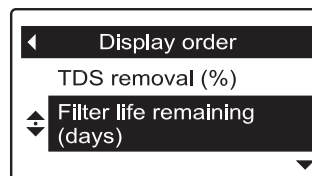

7. Press the UP (▲) or DOWN (▼) buttons to move the item higher or lower in the list.

8. When the item is where you want it in the list, press the SELECT (○) button. The arrows next to the item will disappear.

9. To move another item, return to Step 5. When finished moving items, press the LEFT (◀) button twice.

CHANGING THE REMOTE DISPLAY (Model HERO-375 Only)

RENAMING A DEVICE

“HERO-375” is the default name in the RO status screen on the remote. This name may be customized (up to 20 characters long) as follows:

1. Press the remote’s LEFT (◀) or RIGHT (▶) buttons to manually advance to the HERO-375 status screen.
2. Press the remote’s SELECT (○) button to display the **HERO-375** menu.
3. Press the DOWN (▼) button to scroll through the menu until **Rename device** is highlighted in a box.

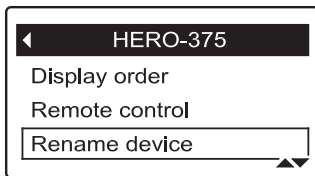

4. Press the SELECT (○) button to display the rename device screen.

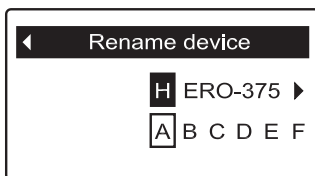

5. Two lines are displayed below the header. The upper line shows the device name. The lower line is the list of available characters (upper and lower case alphabets, space character, numbers and common punctuation marks). Use the RIGHT (▶) or LEFT (◀) buttons to highlight the first character you want to replace in the old device name.

6. Press DOWN (▼) to switch to the lower line.
7. Press the RIGHT (▶) or LEFT (◀) buttons to scroll through the character list. Stop when the character you want to select is highlighted.

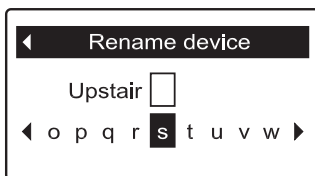

8. Press the SELECT (○) button. The character you picked is added to the upper line.
9. To select the next character, return to Step 7. When finished entering the device name, press the UP (▲) button to switch to the upper line, then press SELECT (○) followed by LEFT (◀).

DELETING A DEVICE

To delete a device from the remote (possible reasons for deleting a device include replacing or upgrading the Hydrolink™ RO Module):

1. Press the remote’s LEFT (◀) or RIGHT (▶) buttons to manually advance to the status screen for the device to delete. The device name will show in the header.

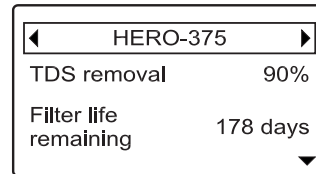

2. Press the remote’s SELECT (○) button to display the device menu.

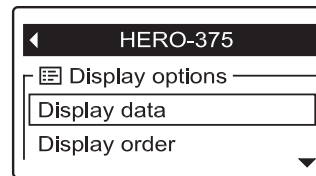

3. Press the DOWN (▼) button to scroll through the menu options until **Delete current device** is highlighted in a box.

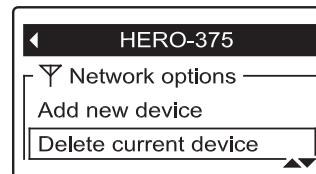

4. Press the SELECT (○) button. The following screen will appear.



5. Press the RIGHT (▶) button. The following screen will appear.

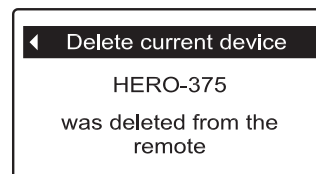

6. To exit this screen, press the LEFT (◀) button.

HOW THE RO SYSTEM WORKS

PREFILTER

Water from the cold supply pipe enters the RO assembly sediment prefilter first. The replaceable sediment cartridge reduces chlorine, sand, silt, dirt, other sediments to clean the feed water before entering the RO cartridge and postfilter.

REVERSE OSMOSIS (RO) CARTRIDGE

The cartridge, inside the RO housing, includes a tightly wound, special membrane. Water is forced through the cartridge and the membrane reduces the dissolved solids and organic matter. High quality product water exits the RO housing and goes to the storage tank, or to the postfilter and RO faucet. Reject water, with the dissolved solids and organic matter, is routed through the flow control and to the drain.

STORAGE TANK

The storage tank holds product water. A diaphragm inside the tank keeps water pressurized when the tank is full, to provide fast flow from the RO faucet. The tank is charged with 5-7 psi air.

POSTFILTER

After leaving the storage tank, but before going to the RO faucet, product water goes through the postfilter. The postfilter is an activated carbon type filter. Any remaining tastes, odors and sediments are reduced from the product water. Clean, high quality drinking water is available for use.

FAUCET

The sink or countertop faucet vends the drinking water when opened. It is opened and closed by turning the knob. To comply with plumbing codes, an air-gap is built into the faucet drain water connection.

ELECTRONICS (HERO-375 Only)

The RO system will monitor the total product flow of the unit and also length of time the filters have been installed. The faucet base has an indicator light that flashes to inform you of the status of the RO membrane and filters.

Green - RO membrane and filters are good.

Amber - Warning, filters need replacing. Filters need replacing, when water has been drawn, after 6 months time (or 650 gallons have been used).

Red - RO membrane needs to be replaced.

When the batteries are first installed at initial start up, the LED indicator light will flash in a red, amber, green sequence. All timers and counters are reset to zero. In order to reset the time and gallon count feature, push the the button on the RO electronics enclosure and hold until the LED flashes, then release.

FIGURE 16

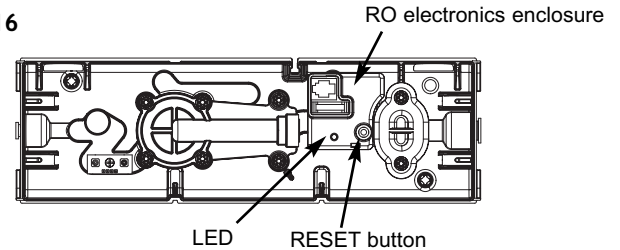
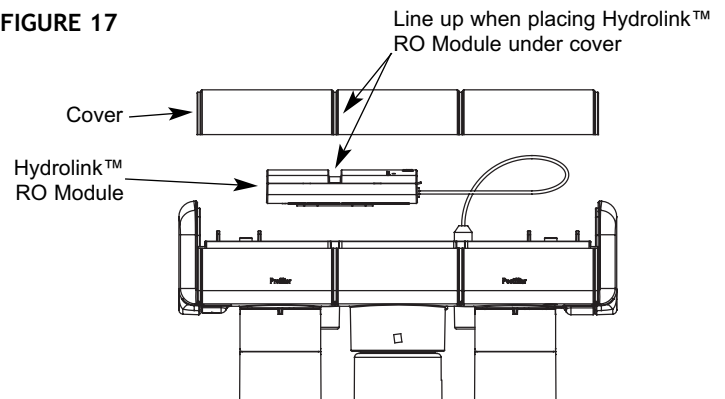

FIGURE 17



SHUTOFF ASSEMBLY

To conserve water, the drinking water system has an automatic shutoff system. When the storage tank has filled to capacity, and the drinking water faucet is closed, pressure closes the shutoff to stop flow into the RO. After drinking water is used, and pressure in the system drops, the shutoff opens to allow water flow again.

CHECK VALVE

A check valve is located in the RO manifold, above the center cartridge. The check valve prevents a backward flow of product water from the storage tank. A backward flow could rupture the RO membrane.

FLOW CONTROL

Water flow through the RO membrane is regulated by the flow control. It maintains the desired flow rate to obtain the highest quality drinking water. The flow control is located in the 1/4" red drain tube. A small cone-shaped screen fits over the end of the flow control to help prevent plugging with drain water sediments.

CARE OF YOUR REVERSE OSMOSIS SYSTEM

To keep your reverse osmosis system operating and producing high quality water, you must make sure supply water is always within the limits shown in the specifications. Good supply water helps to assure longer life from the RO membrane cartridge, prefilter and postfilter cartridges. However, each of these will wear out in time and need replacement.

This reverse osmosis system contains a replaceable treatment component critical for effective reduction of total dissolved solids. The monitor faucet feature provides continuous analysis of the systems performance. For systems not equipped with the monitor faucet function, it is highly recommended that you have your water tested at least every 6 months to verify your system is performing properly. Test kits are available by calling 1-800-949-8220, or check the water testing section of your local phone directory.

If the RO assembly is wall mounted, you may be able to replace parts with the assembly left on the wall. If not, simply lift the RO assembly from the mounting washers and lay on the cabinet floor when replacing the prefilter and post filter cartridges and RO membrane.

FIGURE 18

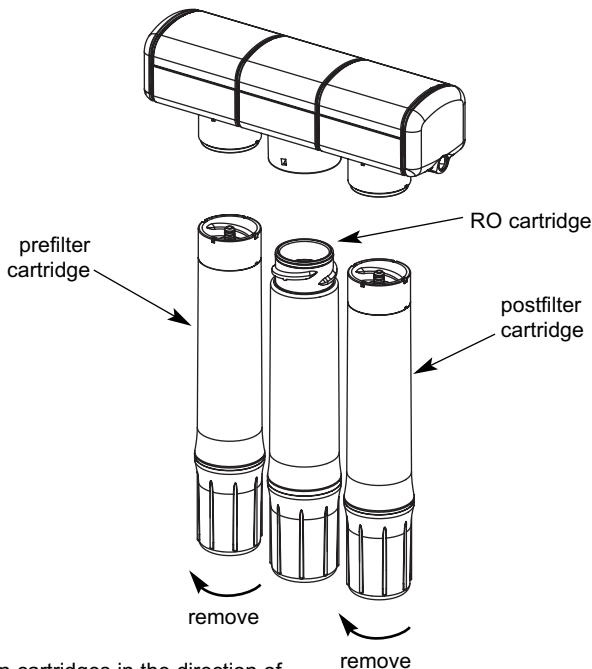

Turn cartridges in the direction of the arrow to remove. Turn opposite way to install and tighten.

PREFILTER AND POST FILTER CARTRIDGES

You must replace the prefilter cartridge often to protect the RO membrane from being destroyed by chlorine, and/or from plugging with sediments in your water supply. If the water supply contains both chlorine and sediments, replace the prefilter cartridge at least every 6 months of product water use. Replace more often than 6 months if it begins to plug with sediments.

If the water has sediments only, with no chlorine, you may notice a slower making of product water as the prefilter collects the sediments. When this occurs, replace the prefilter cartridge. Also replace the post filter cartridge.

To replace the filter cartridges, see Figure 18:

1. Remove (turn to the left) the prefilter cartridge from the filter head.
2. Remove the postfilter cartridge (turn to the left) the postfilter cartridge from the filter head.
3. Discard both cartridges in a proper manner.
4. Insert new cartridges, starting with the post filter, turning to the right to reattach the cartridges.
5. On the HERO-375, press and hold the button on the RO electronics enclosure until the green light begins flashing. Release the button as soon as the light begins flashing (the light flashes for 3 seconds and releasing the button before or after that 3 seconds will not reset the electronic timer).
6. It is recommended to discard the first full tank after the filters have been changed to minimize carbon fines.

RO MEMBRANE CARTRIDGE

This reverse osmosis system contains a replaceable component critical to the efficiency of the system. Replacement of the reverse osmosis component should be one with identical specifications, as defined by the manufacturer, to assure the same efficiency and contaminant reduction performance.

The life of the RO membrane cartridge depends mostly on the pH and hardness of the supply water to the RO system (see specifications). Cartridge life is shorter with higher pH. For example, if supply water pH is from 6.8 to 7.7, the cartridge may last for well over one year. However, cartridge life may be as short as 6 months if the pH is as high as 8.5 to 10. Higher pH weakens the cartridge membrane and causes pin-hole leaks.

continued on Page 20

CARE OF YOUR REVERSE OSMOSIS SYSTEM

continued from Page 19

It's time to replace the RO cartridge when the red LED flashes or the production rate and/or quality of product water drops. Product water may begin to taste different or bad, indicating solids and organics are passing through the RO membrane. When replacing the RO cartridge, replace the prefilter and postfilter cartridges as well.

To replace the RO cartridge (see Figure 18):

1. Remove (turn to the left) the pre filter cartridge from the filter head to relieve pressure on the Reverse Osmosis cartridge.
2. Remove the RO cartridge.
3. Remove the post filter cartridge.
4. Discard the cartridges in a proper manner.
5. Install new cartridges in reverse order (post filter, Reverse Osmosis and then prefilter). Turn cartridges to the right to re-attach to the filter heads.
6. On the HERO-375, press and hold the button on the RO electronics enclosure until the green light begins flashing.
7. Purge the RO membrane cartridge following instructions on Page 11.

FLOW CONTROL

The flow control is vital for proper operation of the RO membrane cartridge. The control keeps water flow through the membrane at the needed rate to obtain the best quality product water.

Periodically check the flow control to be sure the small hole through it is clean and unrestricted.

AUTOMATIC SHUTOFF / PADDLEWHEEL SERVICE

If either the shutoff assembly or paddlewheel requires service, be sure to reassemble parts exactly as shown below.

FIGURE 20

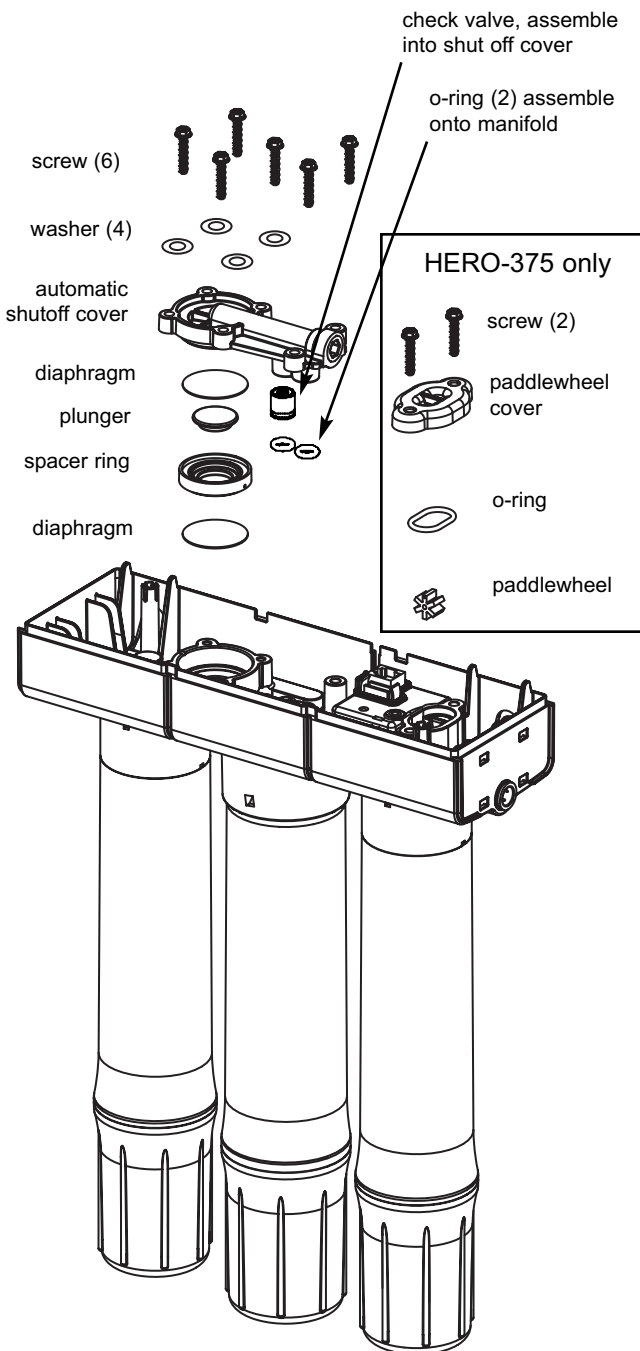
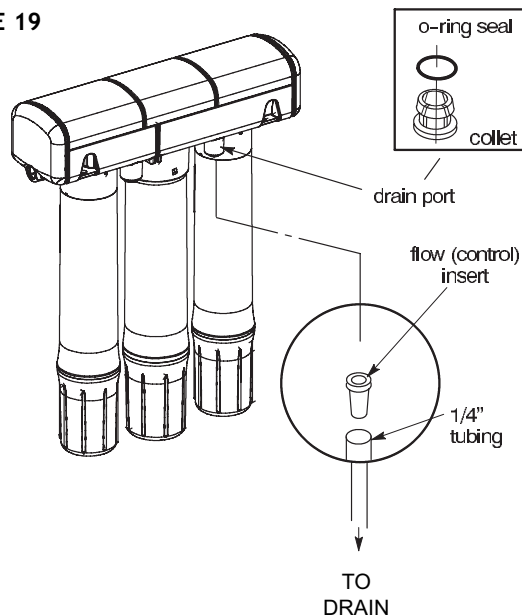

FIGURE 19



CARE OF YOUR REVERSE OSMOSIS SYSTEM

FILTER CHANGE ALERT LED (HERO-375 only)

The Model HERO-375 provides the option of alerting you to the need for a filter change at either 6 or 12 month intervals. The timer is factory set to 6 months. The recommended interval is 6 months, but certain water conditions may allow a 12 month setting. Consult a water professional to determine the proper interval.

NOTE: Please read the following 3 steps and study the order of events in the table at right before starting.

1. Remove the top cover and locate the RESET button on the RO electronics enclosure.

FIGURE 21

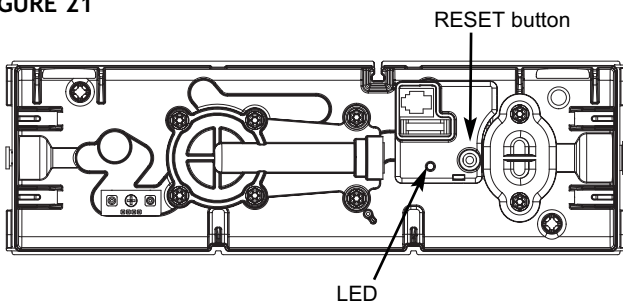

2. To change from 6 to 12 months, press and continue to hold down the RESET button. **Watch the LED during this process.** The LED will go on steady, then flicker, then go off for 6 seconds (See chart at right). When the LED begins to blink (after button has been held down for about 12 seconds), immediately release the button.

3. Once the button is released, the LED will show several double blinks to indicate that the timer has been set to 12 months.

To change back to 6 months:

To change the unit back to 6 months, repeat the sequence, holding down the RESET button for 12-15 seconds, until the light begins to blink. Once the button is released, the light will show several single blinks to indicate that the timer has been set to 6 months.

Order	RESET Button	LED
1	-	● OFF
2	Press & Hold	○ ON (Steady)
3	Continue Holding	⊚ Flicker
4	Continue Holding	● OFF (for 6 sec.)
5	Release Now	⊚ Single Blink or Double Blink
6	-	⊚ Double Blink (set for 12 mo.) or Single Blink (set for 6 mo.)
7	-	● OFF

CARE OF YOUR REVERSE OSMOSIS SYSTEM

REVERSE OSMOSIS SYSTEM CARE GUIDE MODEL NOs. ERO-375 & HERO-375

1. AT LEAST every 6 months, replace the prefilter and postfilter cartridges or when yellow LED flashes or remote indicates "Replace filters".	
2. Replace the RO membrane cartridge when the percent rejection of total dissolved solids (TDS) is less than shown in the specifications (see B , below) or when red LED flashes or remote indicates "Replace membrane".	
3. Replace the batteries once per year or when remote indicates "Replace batteries".	
If any of the following occur before the 6 months, replace as directed.	
A. Slow Making of Product Water: Replace the prefilter cartridge. If the production rate does not improve, replace the post filter cartridge and RO membrane cartridge.	C. Chlorine Taste and/or Odor: Replace the prefilter, post filter and RO membrane cartridges.
B. High Total Dissolved Solids (TDS) in Product Water: If water quality is in question, contact your local EcoWater dealer for testing. It is important to test both the treated and untreated water to determine system performance. If the TDS is not within the system's performance guidelines, replace the prefilter, post filter and RO membrane cartridges.	

OTHER TROUBLESHOOTING

PROBLEM	CAUSE	CORRECTION
Chlorine taste and/or odor in the RO product water.	The amount of chlorine in your water supply exceeds maximum limits, and has destroyed the RO membrane.	If the water supply contains more than 2.0 ppm of chlorine, additional filtering of the water supply to the RO is needed. Correct this condition before doing maintenance on the RO system. Replace the prefilter, post filter and RO membrane cartridges.
	The prefilter is no longer reducing chlorine from the water supply.	
Other taste and/or odor.	Post filter expended.	Replace the post filter cartridge. If taste and odor persists, replace the prefilter cartridge and RO membrane cartridge. Use sanitizing procedures. Replace the post filter cartridge.
	RO membrane cartridge expended.	
	Contamination in product water storage.	
System makes product water too slowly.	Water supply to the RO system not within specifications.	Increase water pressure, precondition the water, etc., as needed to conform before doing maintenance on the RO system. Replace the prefilter cartridge. If rate does not increase, replace the postfilter cartridge and RO membrane cartridge. Check and clean Flow Control Insert.
	Prefilter or RO membrane cartridges plugged with sediments or fouled.	
	Flow Control Insert plugged.	
System makes lower amount of product water than usual.	Storage tank air-charge less than 5 - 7 psi.	Open RO faucet and drain tank until flow slows to a drip. Keep faucet open and check tank pressure. If low, pressurize to 6 psi. Close faucet to refill the tank.
High total dissolved solids (TDS) in product water - flashing red LED.	Water supply to the RO system not within specifications.	Increase water pressure, precondition the water, etc., as needed to conform before doing maintenance on the RO system. Replace the prefilter, postfilter and RO membrane cartridges, flow control, and screen.
	RO membrane cartridge expended.	
Water leaking from faucet airgap hole.	Drain side of faucet airgap (3/8" tubing) plugged, restricted, or incorrectly connected to drain point.	Inspect and eliminate restriction or plug. Refer to installation instructions for proper drain connection.
Continual water flow to drain.	Check valve or automatic shutoff assembly plugged, restricted or parts worn.	Clean, repair or replace as needed.
Faucet LED indicator light does not function after battery change.	Batteries dead.	Replace with new batteries.
	Batteries installed incorrectly.	Install batteries correctly.
Continual high water flow to drain and no product water.	Missing flow restrictor in red drain tube or its corresponding port.	Replace flow restrictor.

REVERSE OSMOSIS SCHEMATIC

FIGURE 22

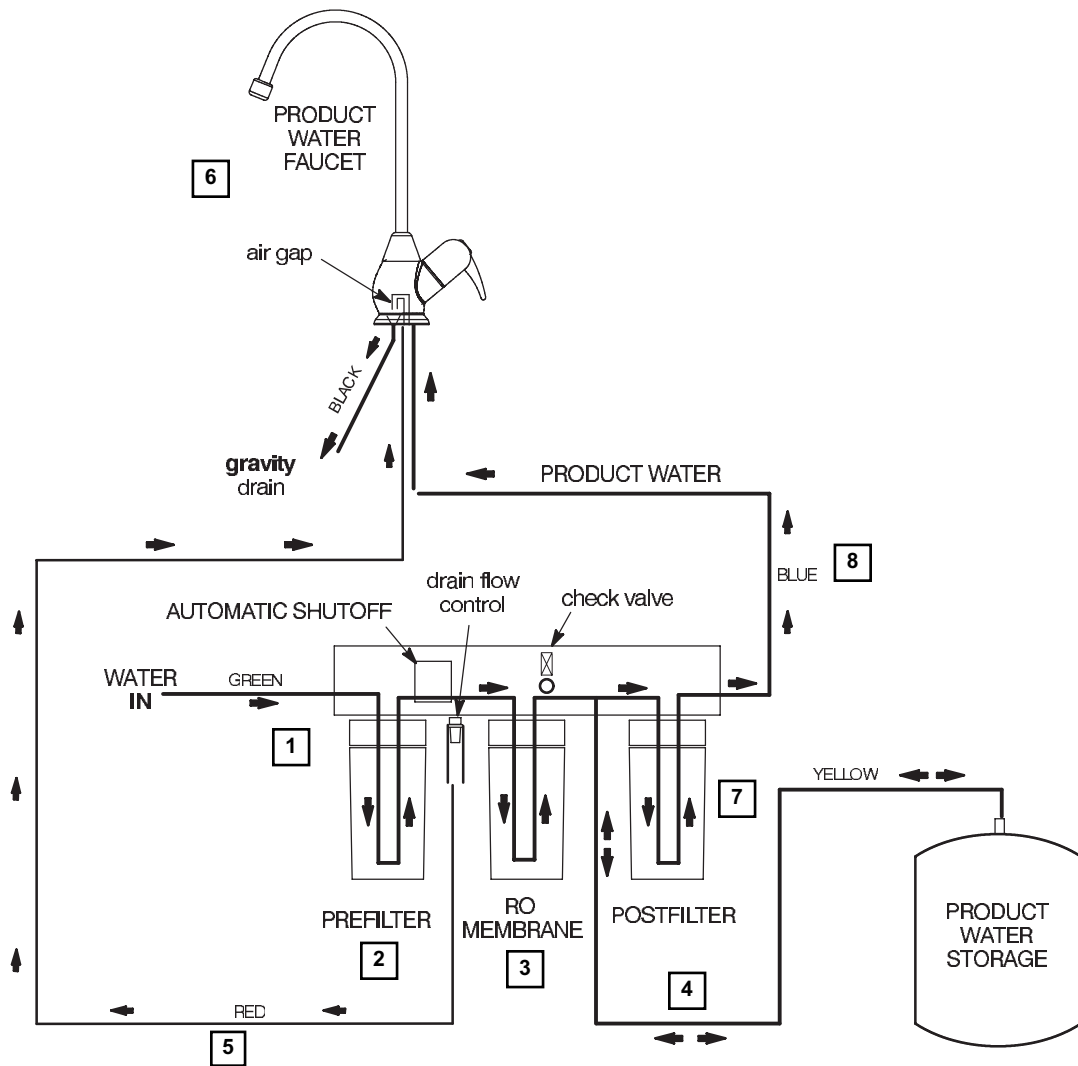

Water Flow Description

1. Water enters prefilter. Sand, silt and other sediments are reduced. Chlorine is also reduced.
2. Water leaves prefilter and proceeds to the Reverse Osmosis Cartridge.
3. Water enters the Reverse Osmosis membrane. Dissolved solids are reduced.
4. Processed water leaves the Reverse Osmosis Membrane and flows to the storage tank.
5. Waste water with dissolved solids leave the Reverse Osmosis membrane and flows to the drain.
6. Faucet is activated.
7. Processed water leaves the storage tank and flows to the post filter filtered to ensure fresh taste.
8. Water flows to the Reverse Osmosis faucet.

INSTALLATION OF OPTIONAL FITTINGS (not included)

SADDLE VALVE, part no. 7011272

NOTE: This valve will pierce a hole in copper tubing or plastic pipe. If installing on iron pipe, you have to drill a 1/8" pilot hole for the piercing pin. Be sure to turn off water to the pipe and to drain water from it before drilling. READ THE FOLLOWING DANGER NOTE.

DANGER (IF DRILLING METAL PIPE): To protect yourself from serious injury or fatal shock, use a battery powered hand drill only to make the hole. Do not use an electric drill.

1. Looking at Figure 23, turn the valve into clamp X and tighten (may be preassembled). Turn the valve handle all the way out.

2. Place the seal on the inside of clamp X as shown. Be sure the piercing pin does not stick out beyond the seal.

3. Place clamp X and Z around the pipe and secure in place with two screws. Tighten both screws evenly, but do not overtighten. Clamp Z will either have threaded screw holes, or two nuts are included.

4. Carefully turn the handle inward to pierce a hole in the copper or plastic pipe.

DRAIN ADAPTER, part no. 7192230

■ The optional drain adapter installs in the sink drain pipe, always above or ahead of the p-trap. Be sure to comply with your local plumbing codes. Other drain pipe fittings, in addition to the adapter, may be needed.

■ The drain adapter fits 1-1/2" sink drain pipe.

■ The adapter installs directly onto the sink tailpiece as typically shown in Figure 23.

■ Locate so drain tubing from the faucet makes a straight run to the adapter, without dips, loops, low spots or kinks.

NOTE: Consult a plumber if you are not familiar with plumbing procedures.

1. Use a ferrule and nut to assemble the drain tubing connector to the drain adapter. Turn the connector to about 45° from the 12:00 position, as shown (to 10:00 or 2:00 position as needed). Tighten the nut securely.

2. Carefully disassemble the sink drain pipe and clean the tailpiece to assure a leak-tight fit.

3. Install the drain adapter onto the sink tailpiece, using a ferrule and nut. Snug the nut, but do not tighten.

4. Assemble the p-trap to the drain adapter, and other drain pipe fittings as required (check codes) to complete the drain run.

5. Tighten all connections, but do not overtighten and break plastic fittings.

FIGURE 23

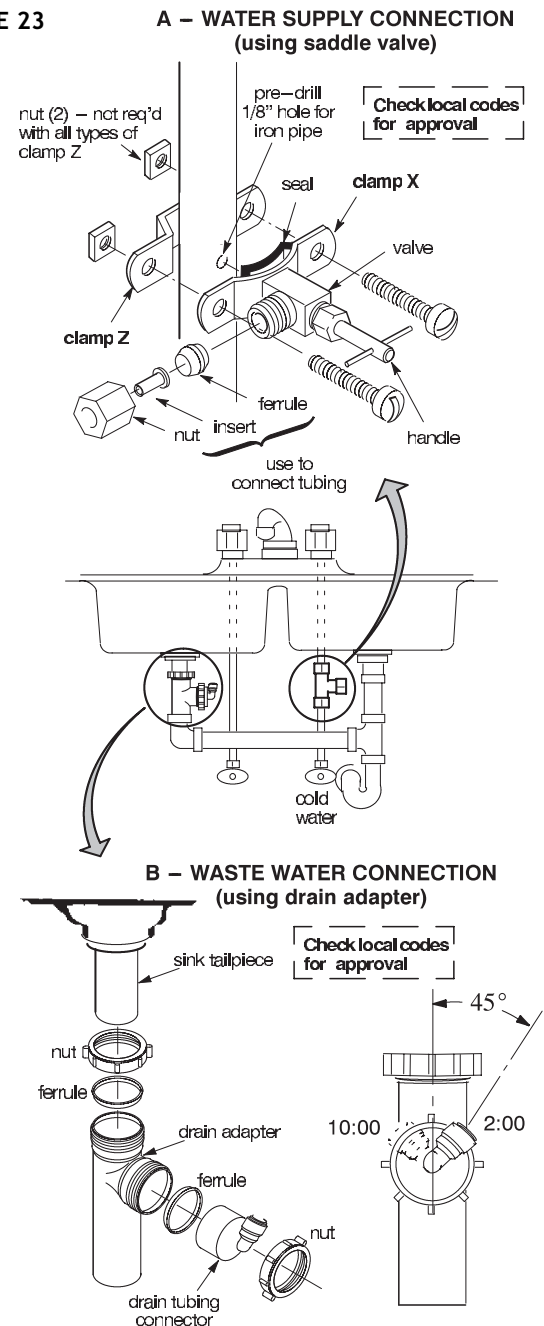

NOTE: Codes in the state of Massachusetts require installation by a licensed plumber, and do not permit the use of a saddle valve. For installation, use plumbing code 248-CMR of the Commonwealth of Massachusetts.

REMOTE LOCATION FOR REVERSE OSMOSIS SYSTEM

Possible remote locations for the RO nearby the kitchen or bathroom sink include;

- (1) a basement area underneath the sink, and
- (2) an adjacent room or closet.

Longer lengths of tubing (see parts list) and telephone cable extension (purchase locally*) may be needed.

You can run the drain tubing directly to one of several suitable open drain points, as shown below, bypassing the faucet airgap and p-trap drain. This type of drain is the preferred over the p-trap drain adapter. Check your local codes. Always be sure to provide an air gap between the end of the hose and the drain point of 2 pipe diameters or 1 inch, whichever is larger.

*Telephone cable extension must consist of a male connector on one end and a female connector on the other to keep proper polarity. Polarity may be reversed if a coupler is used and monitor will not work.

FIGURE 24

Note: Tubing colors as supplied with RO system.

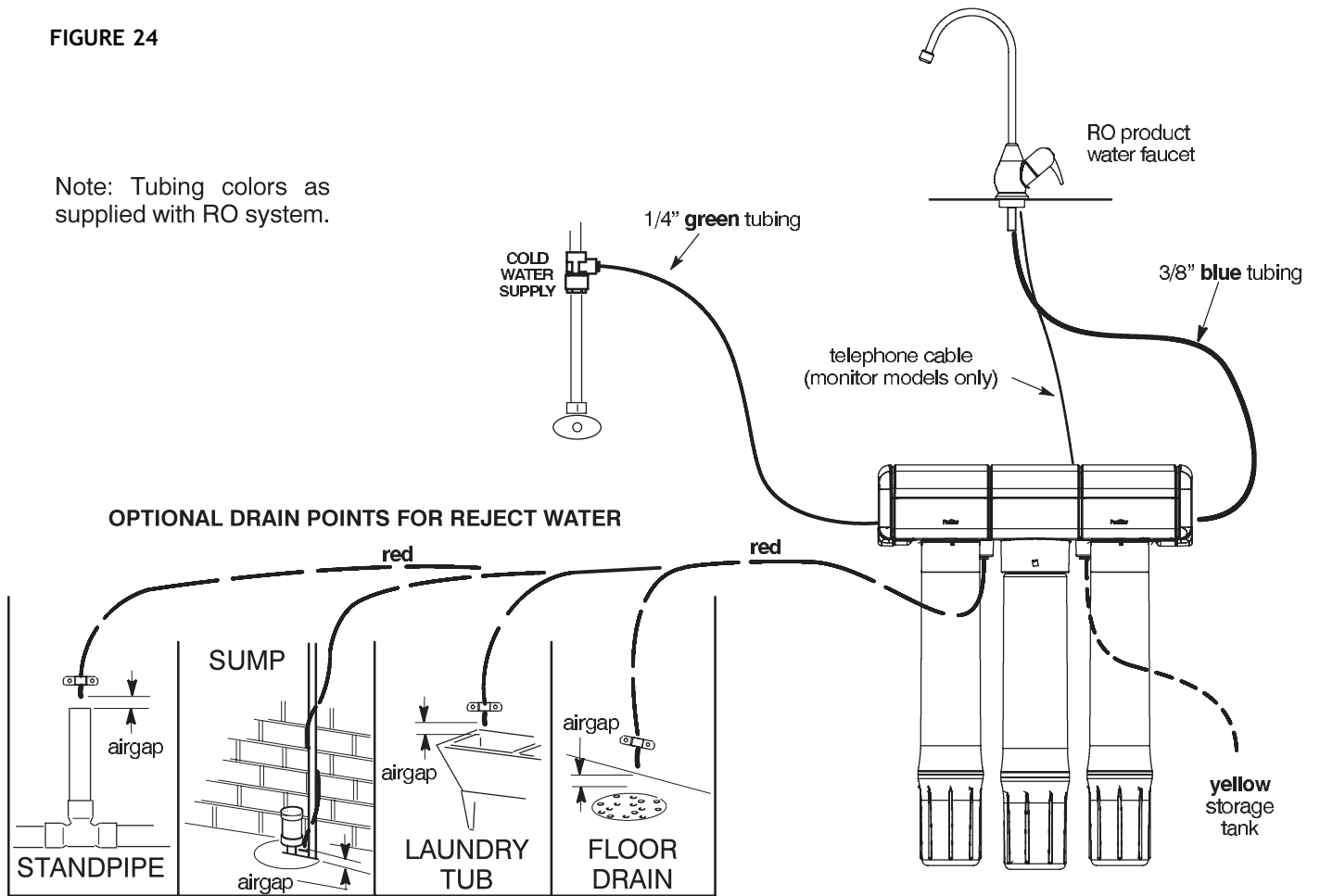

REPAIR PARTS

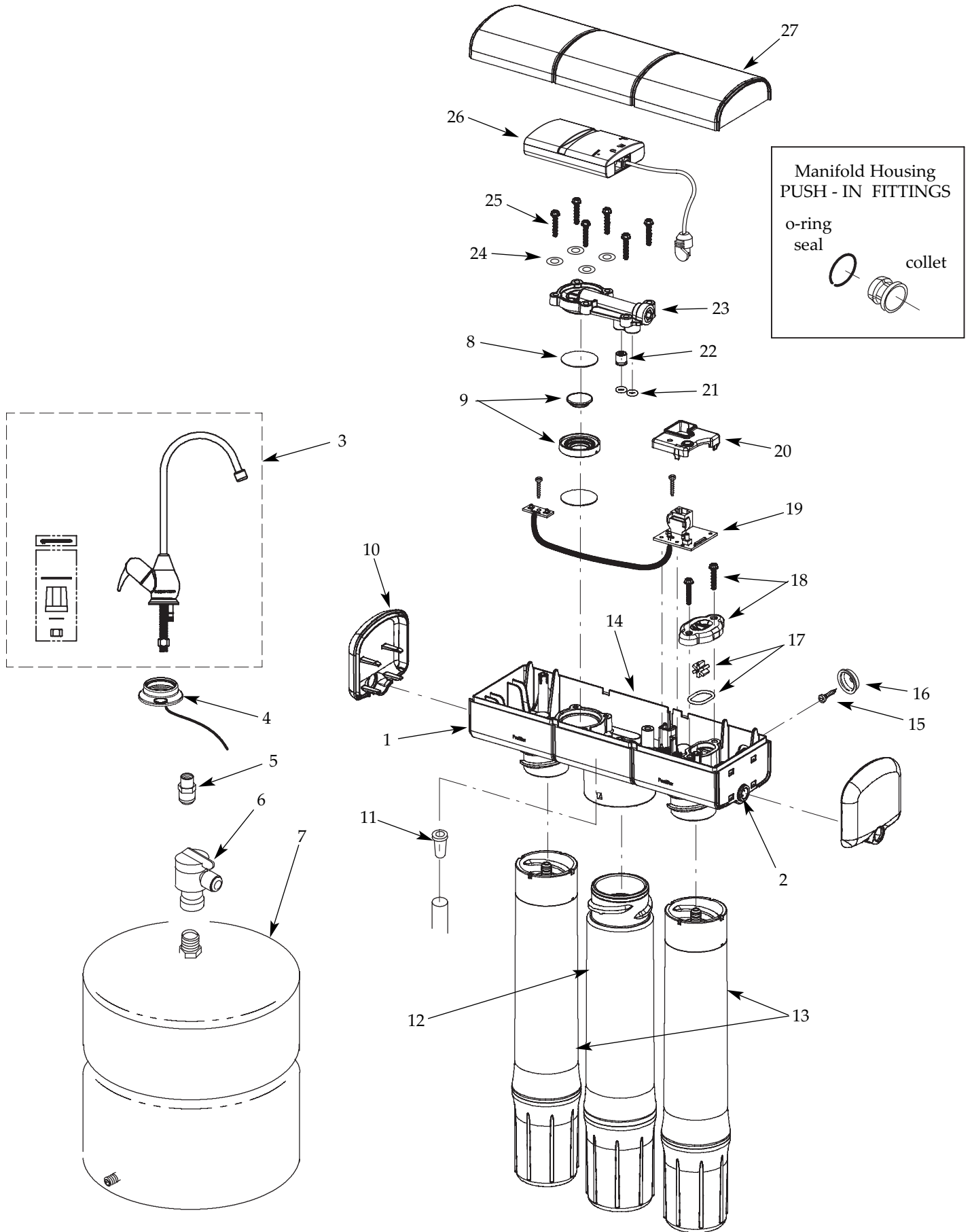

REPAIR PARTS

Key No.	Part No.	Description
1	7281005	Push-in Fitting Kit, 1/4" ❖ ■
2	7281013	Push-in Fitting Kit, 3/8" ❖ ■
3	7272959	Faucet, Chrome
	7277187	Faucet, Brushed Nickel
	7277195	Faucet, White
	7293379	Faucet, Oil Rubbed Bronze
	7293387	Faucet, Black
4	7261500	Electronic Monitor Kit, Chrome, HERO-375 only
	7278230	Electronic Monitor Kit, Brushed Nickel, HERO-375 only
	7278248	Electronic Monitor Kit, White, HERO-375 only
	7291050	Electronic Monitor Kit, Oil Rubbed Bronze, HERO-375 only
	7293646	Electronic Monitor Kit, Black, HERO-375 only
5	7207920	Connector, 7/16-24 x 3/8 Q.C. Tube
6	7251034	Connector, 1/4 NPT x 3/8 Q.C. Tube
7	7256018	Storage Tank
8	7250876	Diaphragm Kit
9	7234325	Plunger & Spacer Ring Kit
■	7095030	Cone Screen
10	7273379	End Cap (2 req'd)
11	7199486	Flow Control Insert
12	7278905	RO Membrane Cartridge
13	7278913	Pre / Post Filter (2 req'd)
14	7285376	Manifold Asm, HERO-375 only (Includes Key Nos. 1, 2, 8, 9, 17, 18, 19, 20, 21, 22, 23, 24, & 25, assembled)
	7285384	Manifold Asm, ERO-375 only (Includes Key Nos. 1, 2, 8, 9, 21, 22, 23, 24, & 25, assembled)

Key No.	Part No.	Description
15	9006062	Screw (2 req'd)
16	9041700	Hanger Washer (2 req'd)
17	7234210	Paddlewheel & O-Ring Kit, HERO-375 only
18	7280164	Paddlewheel Cover (includes screws), HERO-375 only
19	7280156	Rep'l PWA (includes screws), HERO-375 only
20	7272593	Cover, PWA (order decal below), HERO-375 only
■	7272608	Decal, PWA Cover, HERO-375 only
21	7115432	O-Ring, Auto. Shut-off Cover (2 req'd)
22	7272658	Check Asm.
23	7273345	Automatic Shut-off Cover
24	7281330	Washer (4 req'd)
25	7273337	Screw (6 req'd)
26	7300516	Hydrolink™ RO Module, with batteries & cable, HERO-375 only
27	7272763	Cover
■	7273565	Flow Bend, 3/8"
■	7273557	Flow Bend, 1/4"

OPTIONAL ACCESSORIES and TUBING

28	7227310	Tee, Feed Adaptor ❖
29	7208489	Drain Adaptor ❖
30	7079791	Drain Clamp ❖
31	7011272	Saddle Valve ❖
■	7301203	Sanitization Kit ❖
■	7161823	Tubing, 1/4" x 20' - white ❖ ●
■	7161784	Tubing, 1/4" x 100' - white ❖ ●
■	7157280	Tubing, 3/8" x 20' - white ❖ ●
■	7161750	Tubing, 3/8" x 100' - white ❖ ●

■ Not illustrated.

❖ Not included.

■ This o-ring and collet are for replacement in the manifold housing only. They do not fit the other push-in fittings, key nos. 5, 6, 28 and 29.

● Tubing lengths for remote installations and for direct replacement for colored lengths of tubing.

To order parts call your local EcoWater dealer or go to www.ecowater.com to locate a dealer in your area.

